



COMPETITIVE ADVANTAGES

ALUTECH SECTIONAL DOORS

- TECHNICAL FEATURES
- SANDWICH PANEL
- DOOR LEAF COMPONENTS
- TRACK AND HANGING SYSTEM
- BALANCING SYSTEM
- SAFETY SYSTEMS
- EASY MOUNTING
- WICKET DOOR
- WIDE RANGE

Modern production is the basis for the high quality of ALUTECH sectional doors

The Alutech Group of Companies produces all main components for sectional doors, i. e. sandwich panels, tracks, end profiles, connecting plates and brackets.

All processes at every manufacturing stage are monitored — from designing to delivery of a ready product to the client.

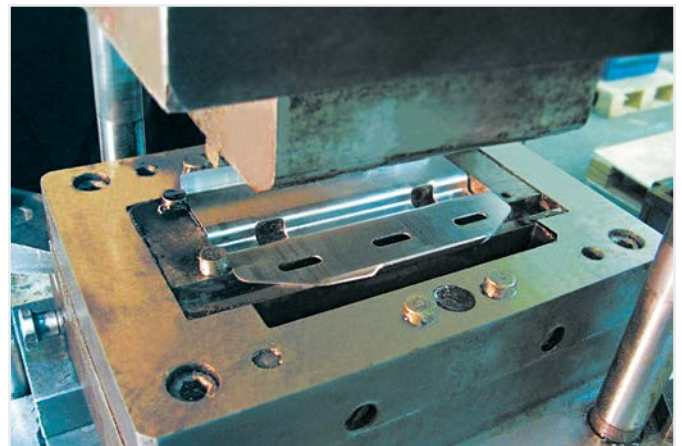

Line for sandwich panel production

ALUTECH sandwich panels are produced on a modern highly-productive line made by the Siempelkamp company (Germany), one of the leading world producers.

The line is universal and produces the entire range of sandwich panels: microwave, S-ribbed, M-ribbed, L-ribbed and cassette ones.

Line for steel profile production

14 types of profiles are produced on the automated roll-forming line (e. g. track profiles, C-profiles, profiles for telescopic hangers, etc.)

Due to the line it is possible to produce steel profiles with high accuracy of sizes and without any damage to the zinc coating.

Line for steel sheet painting

Production capacity of the line for steel sheet painting is 70 000 tonnes a year.

The steel sheet supplied in rolls undergoes multiphase preparation and special treatments that provide all necessary surface characteristics (colour, texture and brilliancy), strength and resistance to abrasions or ultra-violet.

Line for steel components production

Connecting plates, brackets for installing torsion shafts and telescopic hangers are manufactured on high-precision equipment designed for forming.

Due to the equipment it is possible to produce components of high quality and to introduce quickly new developments.



COMPETITIVE ADVANTAGES OF ALUTECH SECTIONAL DOORS



ALUTECH sectional doors—modern, reliable and convenient garage and industrial doors

The innovative approach to the design and production of every unit of ALUTECH sectional doors ensures easy installation, high technical and operational characteristics.

Durability and safety of doors depends on:

1. door leaf design;
2. track design;
3. balancing system of door leaf (torsion springs or tension springs);
4. safety devices.



ALUTECH sectional doors fully comply with all the requirements of European safety standards:

- EN 13241-1;
- EN 12604;
- EN 12453;
- EN 12424;
- EN 12425;
- EN 12426.

Tests confirmed by accredited laboratory Rosenheim GmbH (Germany).

CE mark indicates that a product is absolutely safe for consumers and environmentally friendly.

1

Technical Features

Vision of a house through thermal camera



Effective heat-insulating

High heat-insulating properties of ALUTECH sectional doors are confirmed by tests conducted by the accredited laboratory of Rosenheim GmbH (Germany).

Thermal transmittance of ALUTECH sectional doors is **1,06 W/(m²K)***, that is comparable to a **60 cm** thick brick wall.

* for garage doors Classic 6000x3000 mm.

Maximum sound insulation class



High sound-insulation

Sound insulation of ALUTECH sectional doors is 24dB (EN ISO 717-1).

The highest class of wind resistance



Maximum wind resistance

Resistance of ALUTECH sectional doors to wind loads is 1000 pascal that conforms to the highest Class 4 (by EN 12424).

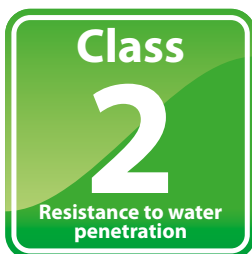

Resistance to water penetration

Resistance to water penetration of ALUTECH sectional doors is 50 Pa, that conforms to Class 2 (EN 12425).



Air permeability

Air permeability of ALUTECH sectional doors conforms to (EN 12426).

Peerless durability

- 1** 45 mm thick sandwich panel is used in ALUTECH garage doors — one of the thickest in Europe. Panel construction ensures high resistance to wind and impact loads.
- 2** High density of polyurethane foam filler (45-47 kg/m³) provides door panel hardness and high resistance to deformation.
- 3** door panel is produced from heavy gauge steel sheet which guarantees high stress-strain properties of doors. The outer steel sheet thickness is:
 - **0,4 mm** for panels with woodgrain embossing;
 - **0,5 mm** for panels with smooth outer surface: S,M,L-ribbed colours Golden Oak, Dark Oak, Cherry, panels M,L-ribbed colours RAL7016 and RAL9016, and also panels L-ribbed colour ADS703.

Multilayer protection

- 1** Two-layer paint coat of **25-35 microns** ensures high panel protection of corrosion:
 - polyurethane coating of **20-25 microns**;
 - primer coating of **5-7 microns**.
- 2** Zinc coating of **16 microns** ensures high anti-corrosion qualities of panels.
- 3** Adhesive coating of **12 microns** provides perfect cohesion of steel sheet and foam, protects panels from inflation caused by the heat of the sun.

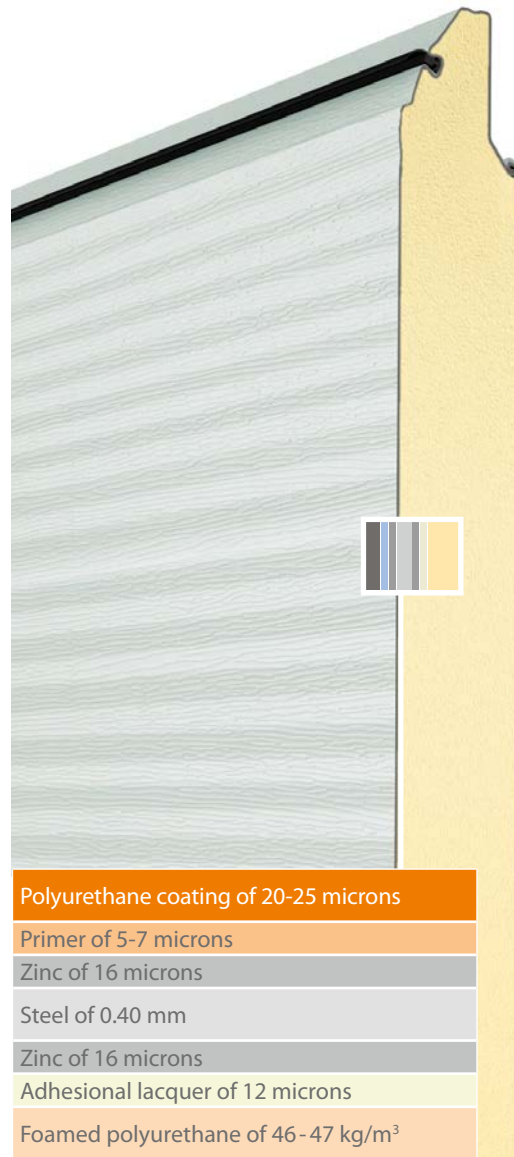

Structure of a steel leaf used for ALUTECH sandwich panels

High quality coating

The front face of ALUTECH panels is finished with a with **polyurethane coating modified by polyamide particles (PUR-PA)** that:

- 1.** is highly resistant to scratches and cuts caused by any mechanical action;
- 2.** is tolerant to temperature and humidity fluctuations;
- 3.** has great strength and elasticity;
- 4.** has excellent anti-corrosion properties;
- 5.** is resistant to detergents and chemicals.

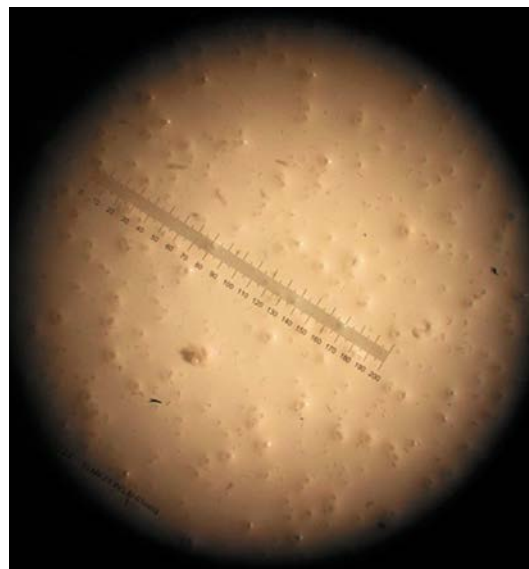

40x magnification of PUR-PA coating under microscope

2

ALUTECH sandwich Panel

Closed contour
of steel sheets

Self-aligning
of panels

Reliable fixture
of hinges

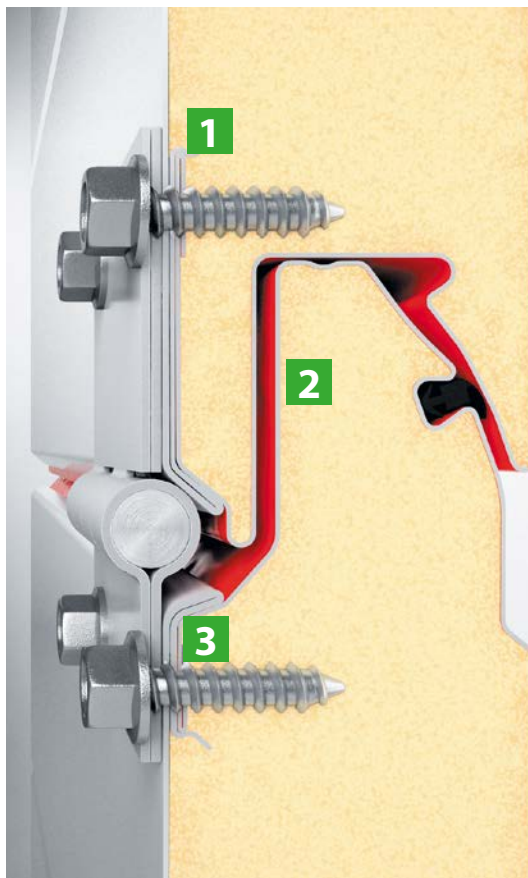

Perfect design of sandwich panels

- 1** Both outer and inner steel sheets of a sandwich panel are interconnected at the top and bottom. This closed contour eliminates separation of a panel due to solar heating something that is very important for southern regions and dark-coloured doors.
- 2** Configuration of panels ensures they are self-aligning. This ensures the door panels are reliably connected to each other and enhances hermeticity and heat insulation of doors. All this makes door installation much easier and avoids errors when assembling a door leaf.
- 3** Places for screws are located where both outer and inner leaves (**4 layers of metal**) are joined. This makes fastening more reliable and minimises hinge sag. Firm joining of steel leaves eliminates panel delamination if a door has been abruptly closed.

Woodgrain
embossment



A good looking door for many years

The exterior side of RAL-coloured panels has a woodgrain embossment. Tiny scratches made in operation become invisible due to the embossment.

S,M,L-ribbed panels colours Golden Oak, Dark Oak, Cherry, M.L-ribbed panels colours RAL9016 and RAL7016, and also L-ribbed panels colour ADS703 have an even outer surface. This gives the doors a more dignified appearance.

Protection against
finger trapping on
inner and outer
side of doors



Operating safety

The design of an ALUTECH panel ensures protection against finger trapping that is the obligatory requirement of European safety norms (EN13241-1).

This protection is highly important for garage doors fitted with a motor.

Corrosion resistance

Independent laboratory testing shows that ALUTECH panel sheet can stand the «salt mist» influence for **750 hours**. This is comparable to **15 years** of operation in coastal areas and contaminated industrial districts.



Corrosion protection

Stainless accessories in a standard set

Intermediate hinges and roller brackets of garage and industrial doors are made of stainless steel. This guarantees high corrosion resistance.



Upper roller bracket of CLASSIC garage doors

Easy regulation

Adjustable roller brackets are used in ALUTECH doors which allows firm adherence of the door leaf to the opening, keeping warmth inside.

Rollers with rolling bearings are used in all brackets which ensure quiet and smooth movement of door leaf.



Side roller bracket of garage doors

Reinforced intermediate hinges

Intermediate hinges are specially constructed as a one piece formation this ensures high strength of hinges and eliminates their sagging and twisting. Tests proved that one intermediate hinge can withstand a tension load of **7000 N** or **~715 kg**.



Intermediate hinge of one piece configuration (for industrial and CLASSIC garage doors)

3

Door leaf components

Elastic EPDM-seal

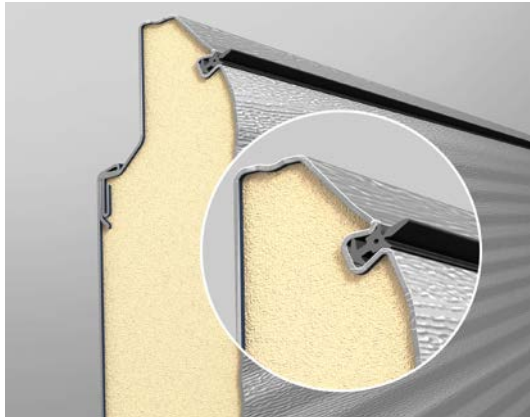

Interpanel seal

Panels are equipped with polymeric **EPDM seals**, that ensure high mechanical rigidity and flexibility in low temperatures. The seal eliminates gaps between panels providing high thermal and sound insulation of doors.

Side double leaf seal

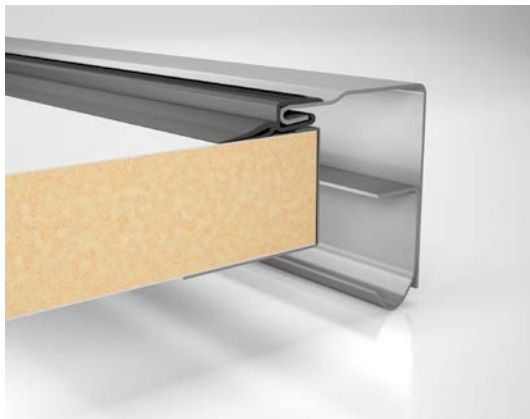

Reliable sealing

ALUTECH sectional doors have special seals made of elastic polymeric rubber located along the entire door perimeter to ensure reliable sealing of openings. Side and upper seals of doors have **two leaves** that ensures better insulation of doors for heat and sound.

Bottom seal (for industrial and CLASSIC garage doors) and plastic stopper

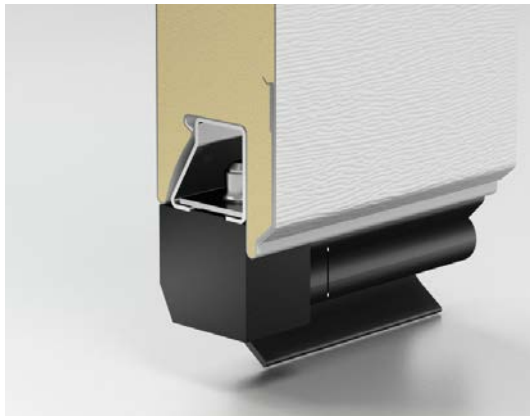

Excellent seal

Elastic and cold-resistant bottom seal due to its form hides slight floor unevenness and hermetically seals the bottom part of the opening.

Plastic stoppers protect a bottom seal from deformation. This ensures a long operational life for the bottom seal.

Hidden bottom end profile



Energy-saving construction

The bottom end profile is totally concealed inside the panel head. The hidden final profile has no contact with the outside preventing thermal bridging. As a result cold does not transmit inside the premises and it does not freeze during the winter season.

Track and hanging system

There are 10 variants of a track system (10 types of installation). ALUTECH doors can be installed in places with a low headroom, a high ceiling or an inclined roof.

Special track system

Angle bars are mounted behind the opening and do not contact with the cold area. This track system construction provides high thermal insulation values.



Angle bar mounting behind the opening

Durable running

Steel horizontal set is both durable and securely constructed giving a long life cycle.

Usage of removable radius elements minimises the risk of damage during transportation.



Steel front assembly

Zinc covering of more than 20 microns

Track profiles are made of high-quality steel with zinc coating of **18-22 microns**. This ensures excellent functionality and good appearance for many years even if operated in humid conditions.



ALUTECH sectional doors installed in a car wash

Robust and reliable joint

Robust and reliable rivset joints are used. Rivset joints don't damage galvanic coating of the profiles which protects them from corrosion.

Absence of lugs provides smooth roller movement.

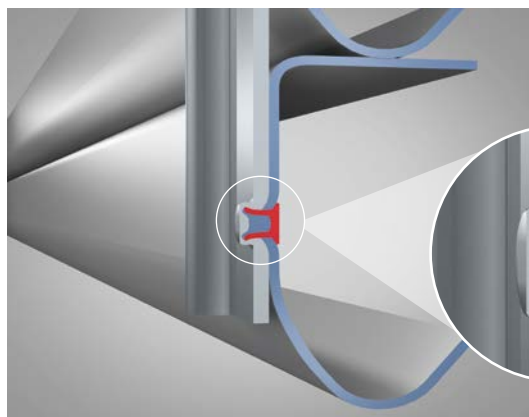

Track rivset-joint

5

Balancing system of a door leaf

Easy to open and close a door



Ideal balancing

The unique ALUTECH estimating program for spring selection ensures an ideal door balance. The necessary effort to open a sectional door is less than 100 — 250 N (**~10-25 kg**), and a door leaf weight is up to 500 kg.

Minimum life time of springs is 25 000 open-close cycles



Long-lasting operational life

Minimum life time of springs for ALUTECH doors is **25 000 of open-close cycles**. This means if you open a door 4 times a day it will operate at least for **17 years**.

If doors are intensely operated (car wash, parking, service stations) spring endurance may be extended up to 50 000, 75 000 and 100 000 open/close cycles.

A spool with a tractive cable

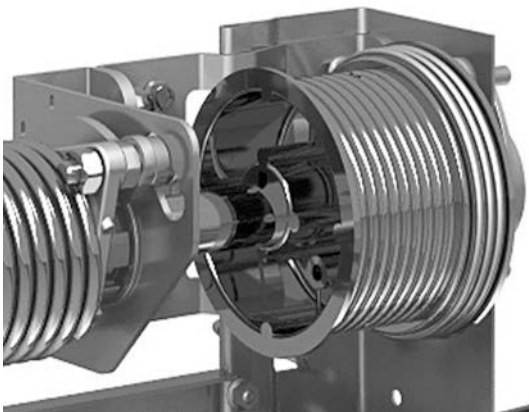

Sixfold safety factor

Steel tension cables with a **sixfold safety factor** are used for ALUTECH doors. This provides protection against cable break and ensures door safety.

Patented method of spring fastening



Spring tension

It is possible to increase or loosen spring tension directly while installing a door or within its operational life. The door will be easily opened and closed for many years.

The unique method of spring fastening is patented.

Extended standard set of garage doors

The standard kit of sectional doors contains a protection system that blocks the shaft and prevents a door leaf from falling if a torsion spring breaks.



Ratchet coupling as protection against door leaf fall in case of spring break



Door leaf prevention from dropping in case a steel cable breaks

The standard set supplied with industrial doors comprises prevention of door leaf from dropping in case steel rope is torn — those are special mechanisms mounted on bottom roller brackets.



Bottom roller bracket to prevent door leaf from dropping in case a steel cable breaks



Safety of doors with drive

An automated industrial door is equipped at no extra surcharge with sensors which monitor cable tension that shuts down a drive, if cables are slackened or broken and if torsion springs break. This ensures complete safety of door operation.



Sensor shuts down a drive in case of spring breakage

Effective safety

The «spring-in-spring» system ensures protection against the door leaf falling as well as against bounce of springs, if one is broken.



The «spring-in-spring» system

7

Easy mounting

Factory-made holes



Holes in panels

Panels are supplied with holes for screw hinges, brackets, locks and other accessories. These factory-made holes make door installation much easier and faster. This is highly important for industrial sectional doors.

Garage door angle profile

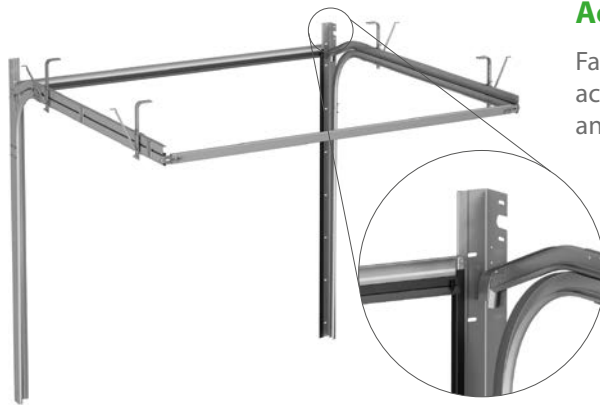

Accuracy in installation

Factory-made holes for track assembling ensures accuracy of door installation and its reliable, safe and silent operation.

Adjustable coupler



Easy regulation of cable tension

Constituent shafts are jointed with an adjustable coupler. This permits shafts to turn independently from each other which ensures the balanced tension of the two lifting cables.

Adjustable telescopic hanger

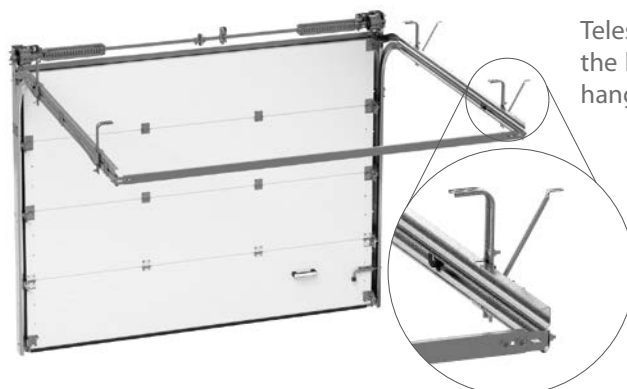

Telescopic hangers

Telescopic hangers allow proper adjustment of the height of horizontal track systems. Telescopic hangers make installation easy and quick.

A wicket door allows you enter and leave the premises without opening the doors. At the same time it helps to keep warmth inside the premises and prolongs the period of operation for the doors.

Innovative approach from ALUTECH offers substantially better operational characteristics of the wicket door

- 1** Narrow profiles of the wicket door framing (40 mm) make it look elegant and attractive;
- 2** Between the panels there are plastic caps which guarantee absence of gaps between profiles of the wicket framing and protection from finger trapping;
- 3** Application of a special safety gear which eliminates sagging of the wicket during use. It guarantees safe and long-term operation of the wicket;
- 4** Above the wicket door curtain from the outside there is a canopy to protect the premises from water when it rains;
- 5** Metal ergonomic handles to ensure safe and long-term operation.
- 6** All doors are equipped with inbuilt sensors that detect the wicket position. The wicket sensor turns off the electric drive if the wicket is open or only partially closed.

You can choose 3 different types of wicket — with flat, low and standard threshold.

Wicket with standard threshold (**145 mm**) has reinforced construction and is installed in doors of maximum dimensions.

Wicket with low threshold (**100 mm**) obey fire safety regulations and can be installed in evacuation routes.

Wicket with flat threshold (**20 mm**) improves door maintenance significantly, providing free passage for trolleys, wheelchairs and bicycles. Can also be mounted on evacuation routes.

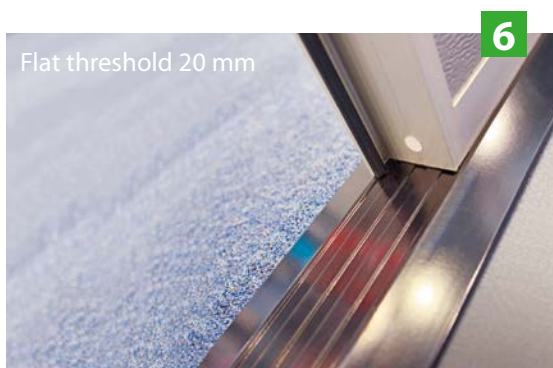

9

WIDE RANGE OF PANELS



L-ribbed S-ribbed M-ribbed Microwave Cassette

Wide range of panel types

We offer **5 types of panels** according to customer's preference: S-ribbed, M-ribbed, L-ribbed, microwave, cassette panels.

The different types of design allow sectional doors to match perfectly any type of finishing.



Wide range of colours

The present standard colour range of ALUTECH doors is represented by 10 colours from the RAL catalogue plus 3 wood finish colours. Doors can be supplied finished in any these **10 standard colours** without any extra-charge.

If the customer desires their doors coated in any RAL colour to harmoniously complement the colour of their windows, roof tiles or the face of the building we can offer the service.

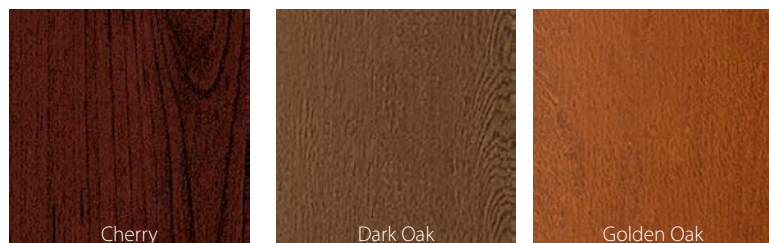

Exclusive design

Sectional doors with woodgrain embossment look as if they are made of one whole piece of wood. Besides this they are more resilient to handling compared with wooden doors and have high thermal insulating values. Panels colours Golden Oak, Dark Oak, Cherry have smooth outer surface.

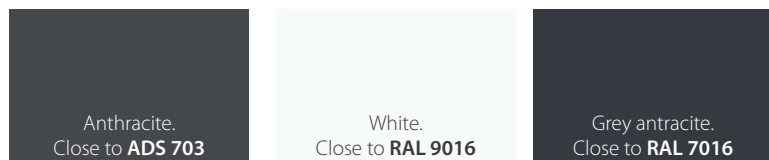

Doors made from panels with a smooth surface (without embossment): S, M, L-ribbed colours Golden Oak, Dark Oak, Cherry, M, L-ribbed colours RAL7016 and RAL9016, L-ribbed colour ADS703 have an especially presentable appearance.



Ample opportunities

ALUTECH doors are manufactured individually for each customer. You may choose dimensions of doors with **5 mm** vertical and horizontal spacing. This permits us to produce the doors for a particular opening.

Combination of different patterns and panel colours will help to choose a solution for any facility. Due to the ability to choose individual designs Alutech sectional doors make it feasible to create unique and original architectural combinations.





Alutech Door Systems



AluminTechno



Alutech Incorporated

The **ALUTECH Group of Companies** is one of the leaders in the production of roller shutter systems and sectional doors systems in Western and Eastern Europe, and a leading manufacturer of aluminum profile systems in the CIS countries. ALUTECH group includes five manufacturing plants, among them there are 3 factories for the production of sectional doors in Belarus, Russia and Ukraine.

All the enterprises of the Group of companies are equipped with high-tech equipment such as:

- two modern lines for the production of sandwich panels;
- roll-forming lines;
- line for coating and cutting of aluminium sheets;
- aluminium extrusion lines;
- automated machines for high pressure casting of aluminium alloys;
- modern powder coating lines;
- the CIS largest complex for anodizing of aluminium profiles.

High-tech equipment and our own manufacturing complexes allow specialists from the **ALUTECH Group of Companies** to control the quality of production at every manufacturing stage: from procurement of raw materials to manufacturing of finished product and its packaging. The quality management system in all group companies meets the requirements of **ISO 9001** International standard in **TÜV CERT** system, which is confirmed by the corresponding certificates.

The **ALUTECH Group of Companies** is actively expanding its markets. Nowadays, **ALUTECH** sectional doors are in demand in the 65 countries around the world: CIS countries and the Baltic, as well as in Germany, France, Austria, Holland, Czech Republic and other countries in Western and Eastern Europe. Products manufactured by the ALUTECH Group of Companies are installed on thousands of enterprises. **ALUTECH** sectional doors perfectly combine comfort, safety, aesthetic quality and style worthy of you and your house.

